

CURRENT 10.0-50.0 Ampere
 VOLTAGE RANG 50 to 1000 Volts

GBPC1501 THRU GBPC5010

FEATURES

- Surge overload -240~500 Amperes peak
- Low forward voltage drop
- Mounting Position : Any
- Electrically isolated base -2000 Volts
- Solderable 0.25" FAST ON terminals
- Materials used carries U/L recognition

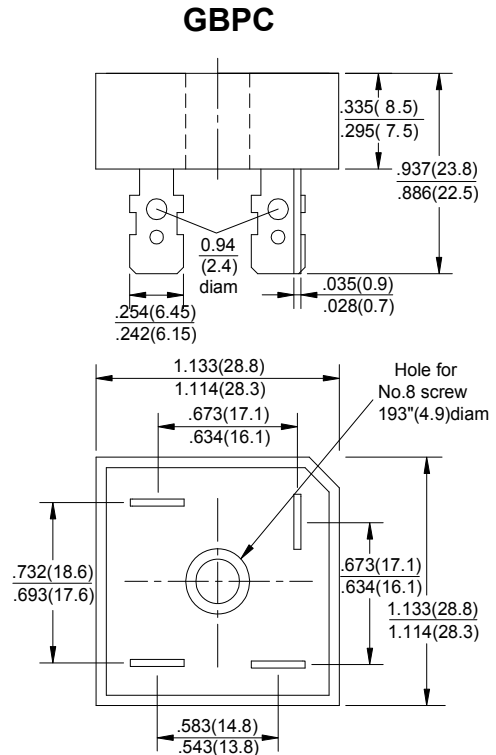

Dimensions in inches and (millimeters)

MAXIMUM RATINGS AND ELECTRICAL CHARACTERISTICS

Rating at 25°C ambient temperature unless otherwise specified.

Resistive or inductive load 60Hz.

For capacitive load current by 20%

CHARACTERISTICS	SYMBOL	GBPC	GBPC	GBPC	GBPC	GBPC	GBPC	GBPC	UNIT			
		10005	1001	1002	1004	1006	1008	1010				
Maximum Recurrent Peak Reverse Voltage	V _{RRM}	50	100	200	400	600	800	1000	V			
Maximum RMS Bridge Input Voltage	V _{RMS}	35	70	140	280	420	560	700	V			
Maximum Average Forward Rectified Output Current @T _c =55°C	I _(AV)	10	15	25	35	50			A			
Peak Forward Surge Current 8.3ms Single Half Sine-Wave Super Imposed on Rated Load	I _{FSM}	10	240	15	300	25	400	35	400	50	500	A
Maximum Forward Voltage Drop Per Element at 5.0/7.5/12.5/17.5/25.0A Peak	V _F	1.1							V			
Maximum Reverse Current at Rate DC Blocking Voltage Per Element @T _J =25°C	I _R	10							μA			
Operating Temperature Range	T _J	-55 to +150							°C			
Storage Temperature Range	T _{STG}	-55 to +150							°C			

CURRENT 10.0-50.0 Ampere
 VOLTAGE RANG 50 to 1000 Volts

GBPC1501 THRU GBPC5010

FIG.1-MAXIMUM FORWARD SURGE CURRENT

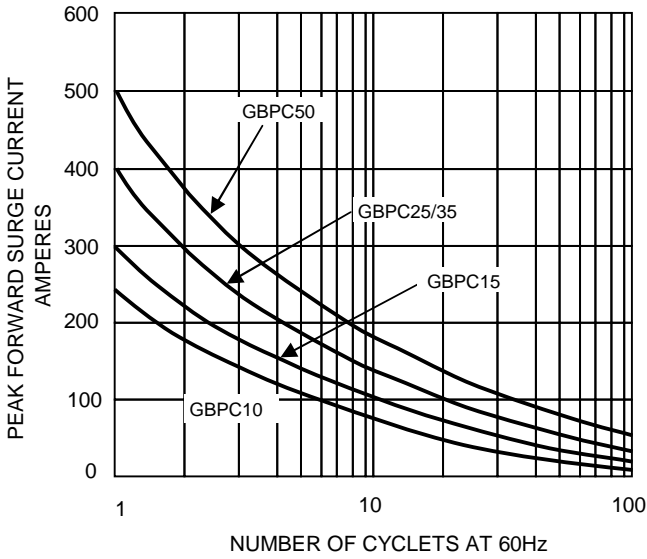

FIG.2- DERATING CURVE
 OUTPUT RECTIFIED CURRENT

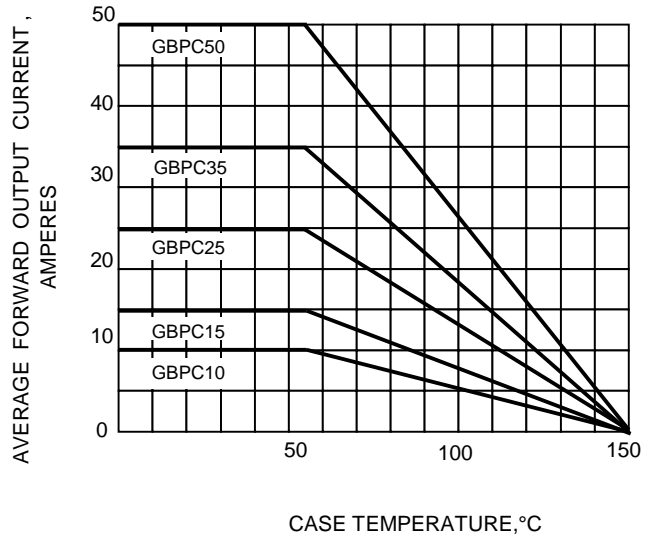

FIG.3-TYPICAL FORWARD CHARACTERISTICS

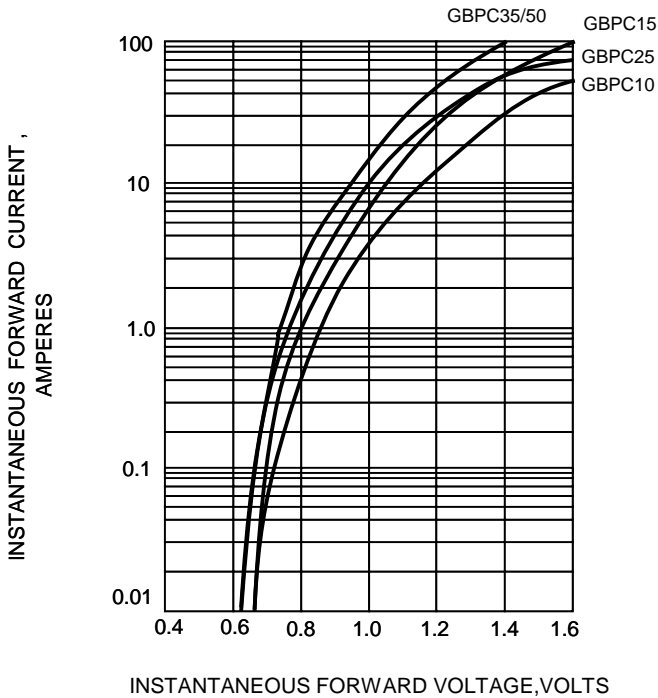

FIG.4-TYPICAL REVERSE CHARACTERISTICS

